

BNWAS

HLD-BNwas 600

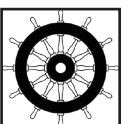

BRIDGE NAVIGATIONAL WATCH ALARM SYSTEM



The HLD-BNWS 600 is Highlander's 2nd generation bridge navigational watch alarm system, a mandatory and highly cost-effective shipboard safety system built with the very best in electromechanical componentry and microelectronic design. Its purpose is to ensure that the watch officer remains alert while on bridge duty, and to immediately notify fellow crew members if he falls asleep or becomes incapacitated.

The BNWS operates on the logic sequence defined in IMO Resolution MSC.128(75) and IEC 62616, whereby the Officer of the Watch (OOV) needs to periodically press a button to reset a countdown sequence. At the end of that sequence – called the "dormant period" (selectable from 3 to up to 12 minutes) – the BNWS flashes lights in the bridge wheelhouse. The OOV then has 15 seconds to press the reset button. If he fails to do so, an audible alarm is sounded only in the wheelhouse. He then has 15 more seconds to press the reset button. If he still does not, a 2nd stage alarm is triggered, whereby loud alarms are emitted by speaker devices fitted in the back-up officer's and/or master's cabins. Finally, there is a 3rd stage alarm in which even more speaker devices, located in the cabins of additional crew members, sound. The 3rd stage alarming is triggered if the system is not reset within 90 seconds of the 2nd stage alarming.

Attributes and Features

- Sleek, stylish design with robust construction
- Highly legible colour touch-screen operation unit, resolution 800 × 480, with distinct day and night display modes
- Simple, intuitive operation. Controls are labelled by both alphanumeric text and graphic icons
- The visual alarm unit uses a revolving mirror-reflector mechanism similar to emergency vehicle warning lights
- Reset units also provide visual and audible alarm functions
- High-sensitivity motion detectors cover large areas and are not prone to false triggering
- Optional high-capacity battery unit guarantees uninterrupted operation
- Signal inputs and outputs via IEC 61162 serial connection and dry contacts

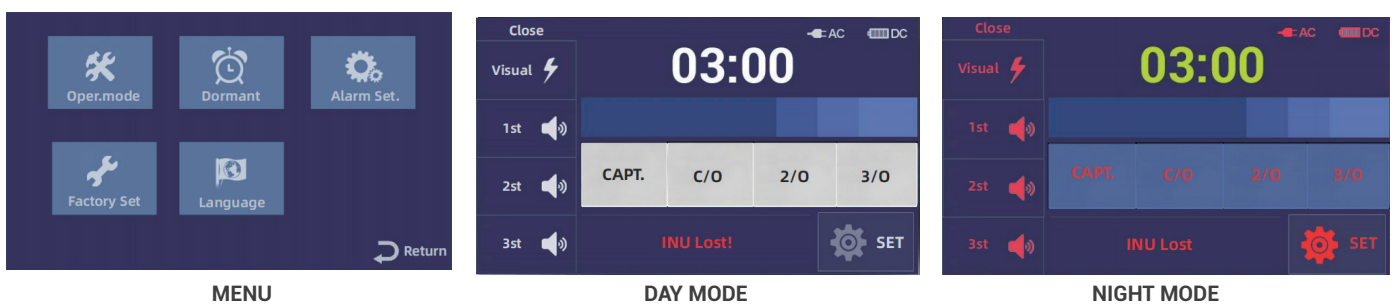

Technical Specifications

- Power Supply: 110/220 VAC, 50/60 Hz and 24 VDC; max. 30 W
- Inputs: GPS: date & time synchronization
Autopilot, Radar, ECDIS: reset signal & back-up officer call
- Output: VDR, external Alarm System

Functions

MODE	FUNCTION	DESCRIPTION
Operational Modes	On	Vessel is at sea.
	Off	Vessel is moored and BNWAS is not needed.
Alarm	Visual Indication	The HLD-BNWAS 600 has a settable dormant period of 3 to 12 minutes (configurable via the operation unit). At the end of the dormant period, the system triggers a visual alarm. The OOW then has 15 seconds to reset (this can also be achieved via the motion sensor).
	First Stage Audible Alarm	If the RESET fails to occur, the 1st stage audible alarm sounds in the bridge wheelhouse (and nowhere else). Once again, the OOW has 15 seconds to perform RESET (this may also be achieved just by his movement).
	Second Stage Alarm Remote Audible	If the RESET still does not happen, the 2nd stage remote audible alarm sounds in the back-up officer and master's cabins. Now the OOW has 90 seconds to perform RESET (this may also be achieved by his movement alone).
	Third Stage Remote Audible Alarm	If RESET has still not taken place, the 3rd stage remote audible alarming commences. The loud alarming in the back-up officer and master's cabins is added more alarming new dormant crew locations.
	Emergency Calling	Pressing the EMERG. CALL key on the operation unit summons the master and back-up officer to the bridge.
	Back-up Navigator Alarm	The back-up officer can be summoned to the bridge through the alarm unit fitted in his cabin.
Resetting	Manual Reset	Method 1 – Operation Unit RESET Key Press the RESET key on the operation unit to dismiss the visual alarm and initiate a new dormant period. Method 2 – Any Key / Touch Screen Press any key on the operation unit or touch any point on the display screen to reset the system. This dismisses the visual alarm and initiates a new dormant period. Method 3 – Remote RESET Button Press the RESET unit button (normally mounted at the bridge control console and/or bridge wings) to dismiss the visual alarm and initiate a new dormant period. Method 4 – Motion Sensor When the motion sensor detects movement, the system automatically resets and initiates a new dormant period.
Connectivity	IEC 61162 Format	VDR or other external devices.
	Dry Contact Signal Output	Central alarm system.

Configuration

Parts	MODE	Dimension/mm (LxWxH)	Weight/kg	Number	Installation	Note
Standard components						
Interface Unit	HLD-INU600	340x235x120	4.5	1	Bridge/Wall Mount	IP22
Operation Unit	HLD-OPU600	165 x165x40	1	1	Flush Mount/Desk Mount	IP22
Alarm Unit	HLD-ALU600	96 x96x60	0.2	5-18	Flush Mount/Wall Mount	IP22
Indoor Reset Unit	HLD-REU601	96 x96x60	0.3	1-2	Flush Mount/Wall Mount	IP22
Outdoor Reset Unit	HLD-REU602	153 x143x63	0.5	2-4	Wall Mount	IP56
Optional components						
Motion Detection Unit	HLD-MDU600	292x179x136	0.2	1-4	Flush Mount / Wall Mount	IP22
Visual Alarm Unit	HLD-VAU600	96 x96x140	0.4	1-2	Flush Mount / Wall Mount	IP22
Battery Unit	HLD-BAU600	340x235x120	10	1	Wall Mount	IP22

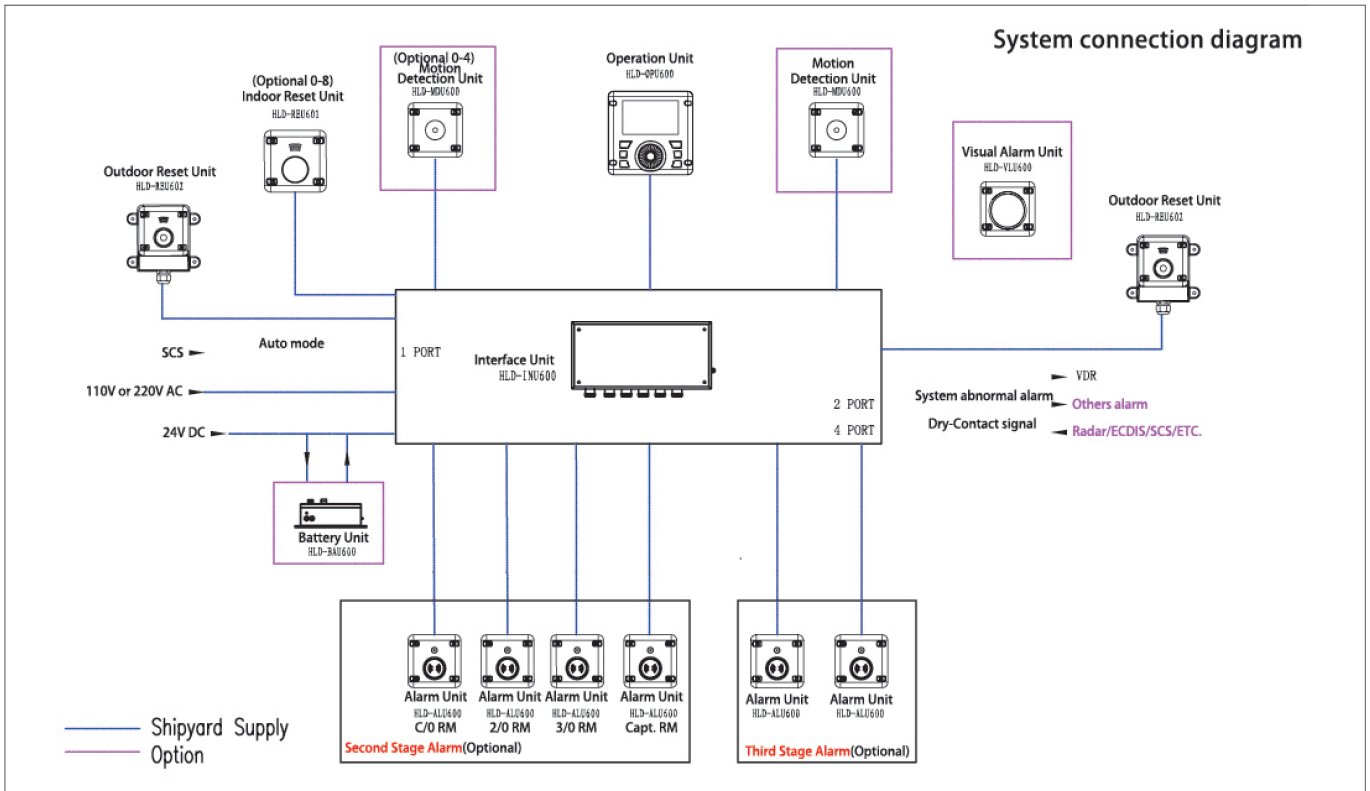

Dimensional Drawings

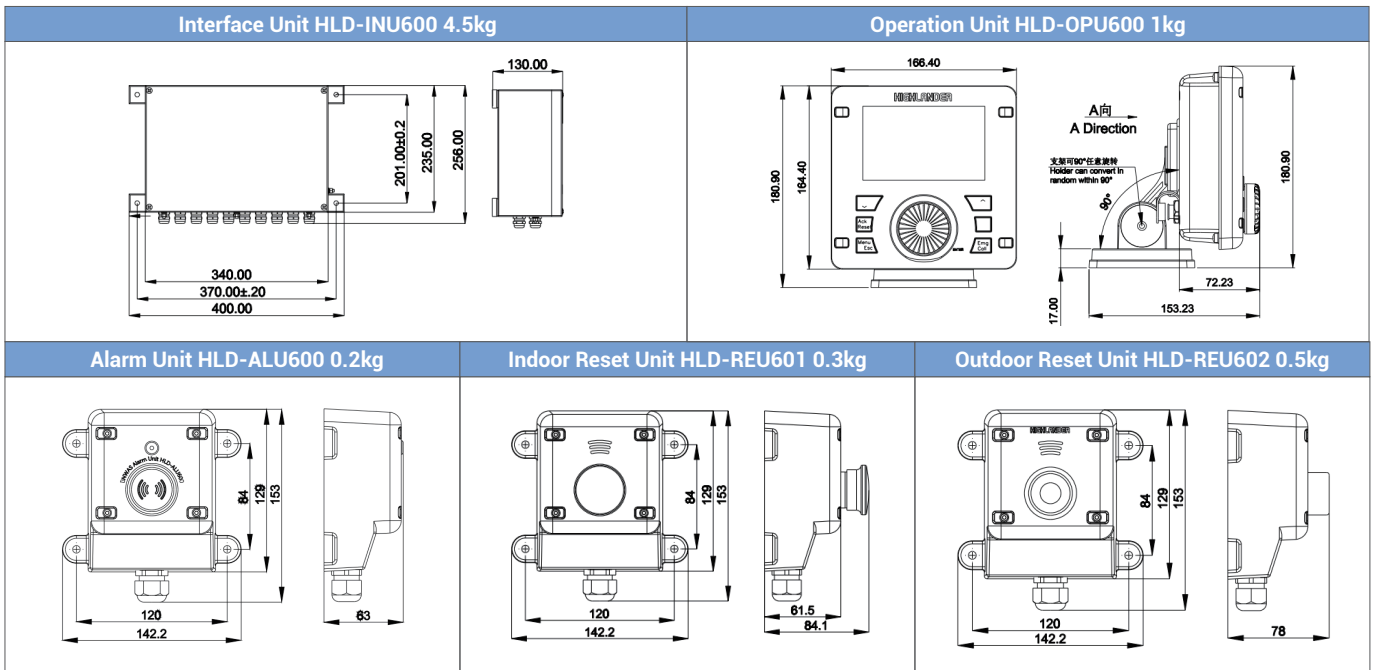

24 Hours
服务热线

Tel: 400 088 3335 / +86 513 8058 2906
E-mail: radar@highlander.com.cn
service@highlander.com.cn

Jiangsu Highland Integration Technology Co., Ltd.
Jiangsu Tusuo Ocean Technology Co., Ltd.

Add: No. 199, Qingfeng Road, Sutong Science & Technology Industrial Park, Nantong City, Jiangsu Province, China

Tel +86 513 80582989

Fax +86 513 80582929

Website www.highlander.com.cn

Post code: 226017